

LM200 MICRO CONNECTORS

High density, 2 mm pitch connectors, with high resistance to vibration and extreme reliability, designed to meet BS9525 F0033 specification.

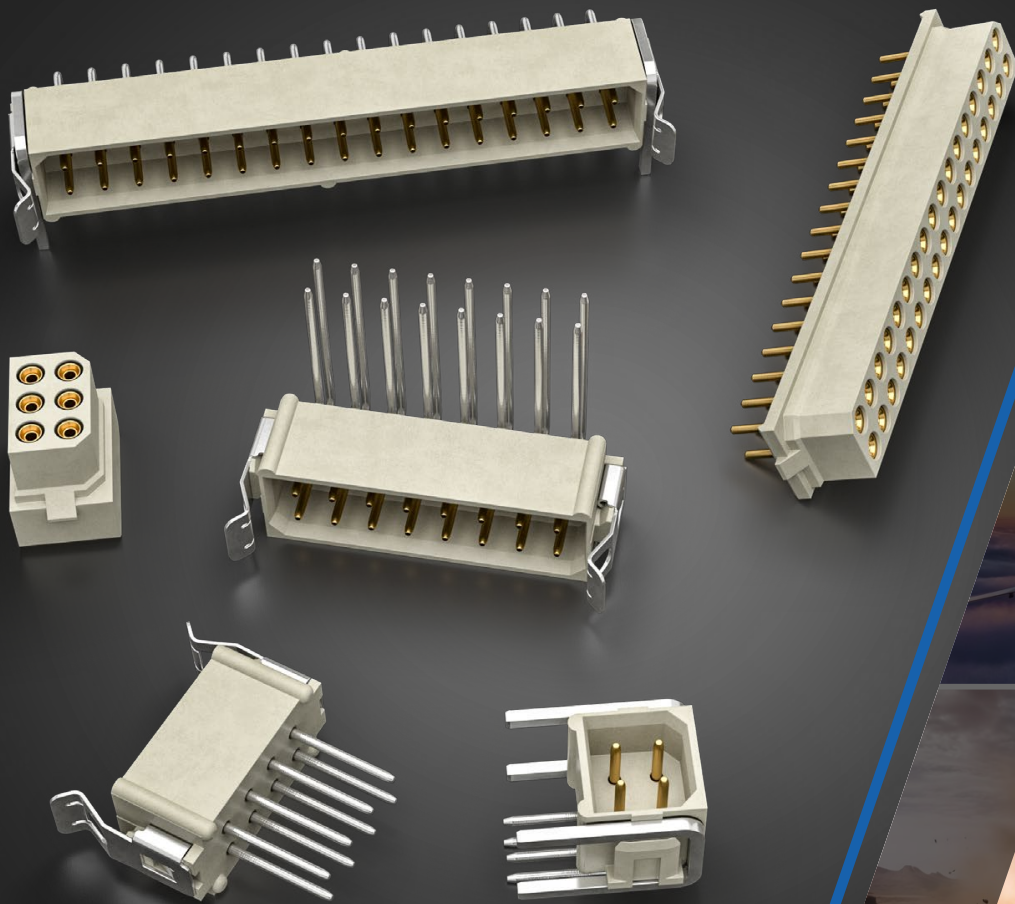

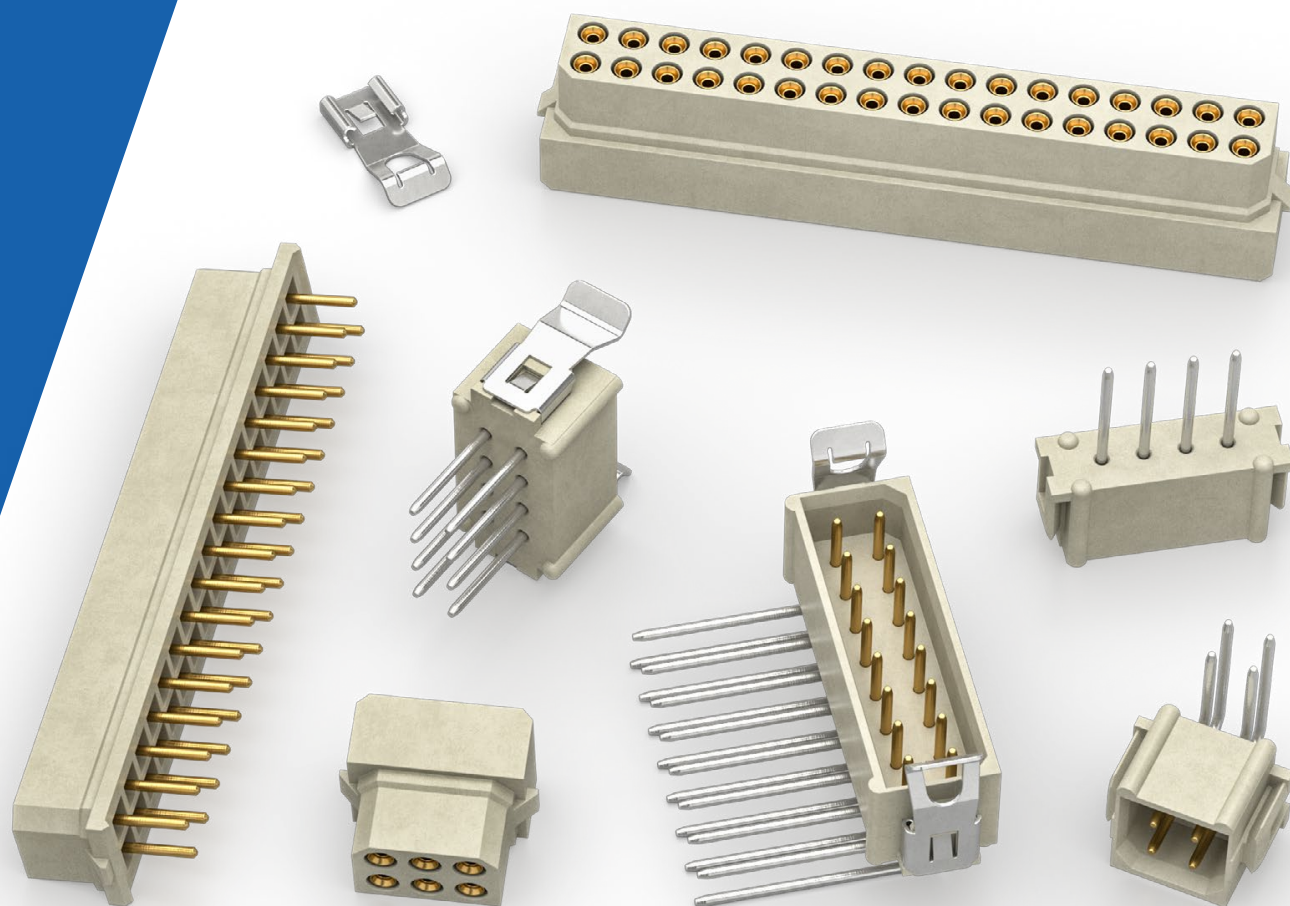

Contents

Introduction	3
General information	4
Features and benefits	4
Characteristics	5
Styles and dimensions	6-7
Minimum spacing	8
Crimp details	8
Contact arrangement	8
Connector ordering information	9
Tool ordering information	9
Product safety information	10

Lodge Group

Established in 1976, Weald Electronics is part of the Lodge Group which includes the connector distributor FC Lane Electronics and its Autosport Division, Lane Motorsport.



Lodge Group Headquarters

Weald Electronics is predominantly known for its comprehensive selection of circular bayonet and screw coupling connectors, and two-part PCB sub-miniature plastic-bodied circular connectors. Weald also specialises in short run, application specific, special and obsolete connector and cable developments.

To complete your interconnection solution, Weald manufactures protective caps and backshells for MIL-DTL-38999 and 26482 applications as well as protective caps, nut plates and gaskets for use right across motorsport.

With design, manufacturing and test facilities at its Slinfold Lodge HQ, Weald Electronics is able to tailor a connector solution to exactly meet a customer's specific requirement on surprisingly short lead times. Standard products are normally available next day.

Products from Weald Electronics Ltd are available from FC Lane Electronics Ltd.

t: +44 (0) 1403 790 661

e: sales@fclane.com

w: fclane.com

General Information

LM200 micro connectors are high density, single row or two row 2 mm pitch connectors, designed to meet BS9525 F0033 specification. They are ideal for board-to-board or board-to-cable applications where high resistance to vibration and extreme reliability are paramount. LM200 micro connectors feature a small footprint for increased packing density.

Features and Benefits

- Design to meet BS9525 F0033 specification
- High density 2 mm pitch 2-part PCB connector
- High specification
- Small footprint for increased packing density
- 7 sizes single row (2 to 17 way), 11 sizes two row (4 to 34 way)
- Male straight and 90° PC terminations
- Female straight PC and crimp terminations
- For board-to-board or board-to-cable applications
- High reliability circular contacts for increased vibration and shock resistance
- Positive latching available

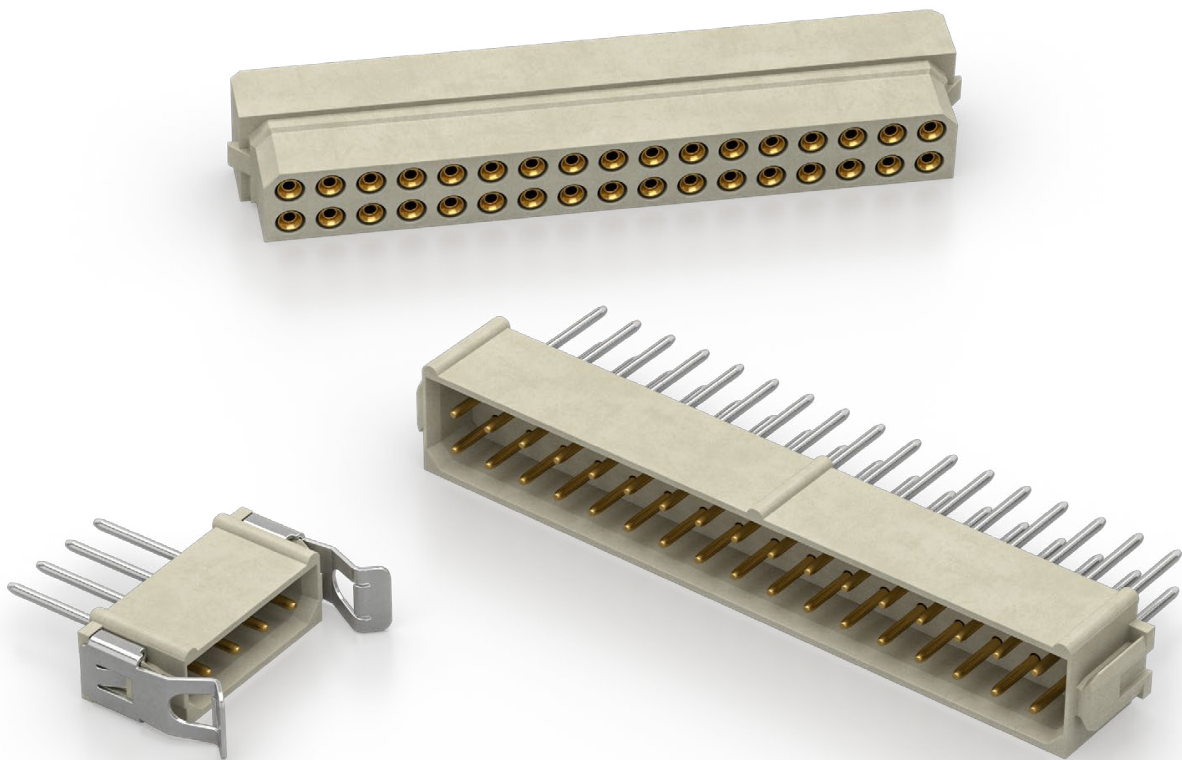

Characteristics

Materials

Insulator	Glass filled thermoplastic rated UL94V-0
Contact	Copper alloy plated hard acid gold
Termination finish	Hard acid gold, tin or tin/lead

Electrical

Current rating - individual contacts (in insulation)	at 25°C Tamb 2.00 amps max at 85°C Tamb 1.75 amps max
Current rating - all contacts (simultaneously)	at 25°C Tamb 1.75 amps max at 85°C Tamb 1.50 amps max
Working voltage DC or AC peak	120 volts
Proof voltage DC or AC peak	360 volts
Contact resistance initially	20 mΩ max
Contact resistance after conditioning	25 mΩ max
Insulation resistance initially	1000 mΩ min
Insulation resistance after conditioning	100 mΩ min

Mechanical

Mechanical operations	500
Insertion and withdrawal force (per contact pair)	2.0 N max, 0.2 N min
Contact retention	10 N min
Crimp barrel accommodation	22 AWG - 28 AWG to BS G 210 Type A

Environmental

Temperature range	-55°C to +125°C
Vibration severity general	10 Hz, 2000 Hz 0.75 mm/98 m/s ² (10g _n) duration 6h
Bump severity	390 m/s ² (40 g _n) 4000 ± 10 bumps
Shock severity	981 m/s ² (100 g _n) for 6 ms
Acceleration severity	490 m/s ² (50 g _n)

Styles and Dimensions

Male straight PC termination type T, X and Y

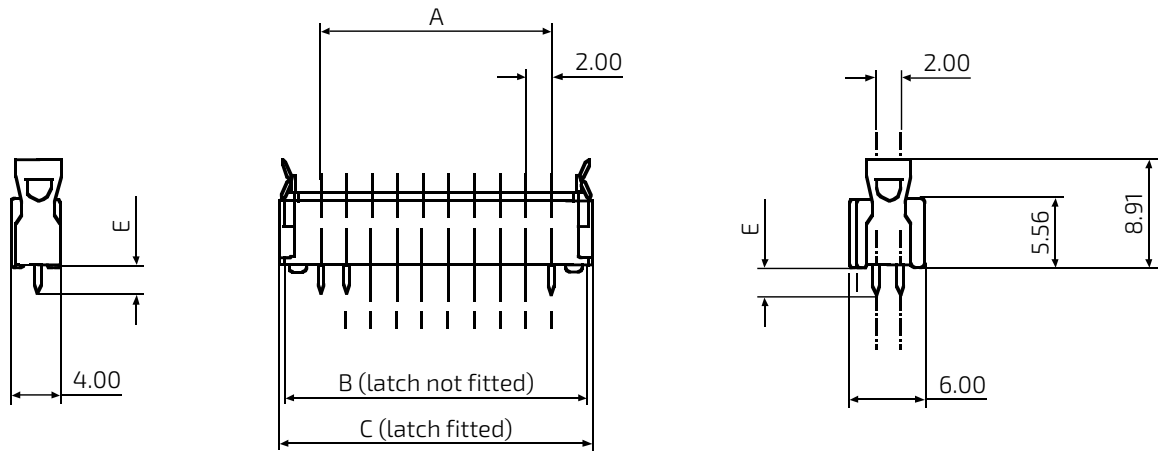

Male 90° PC termination type L

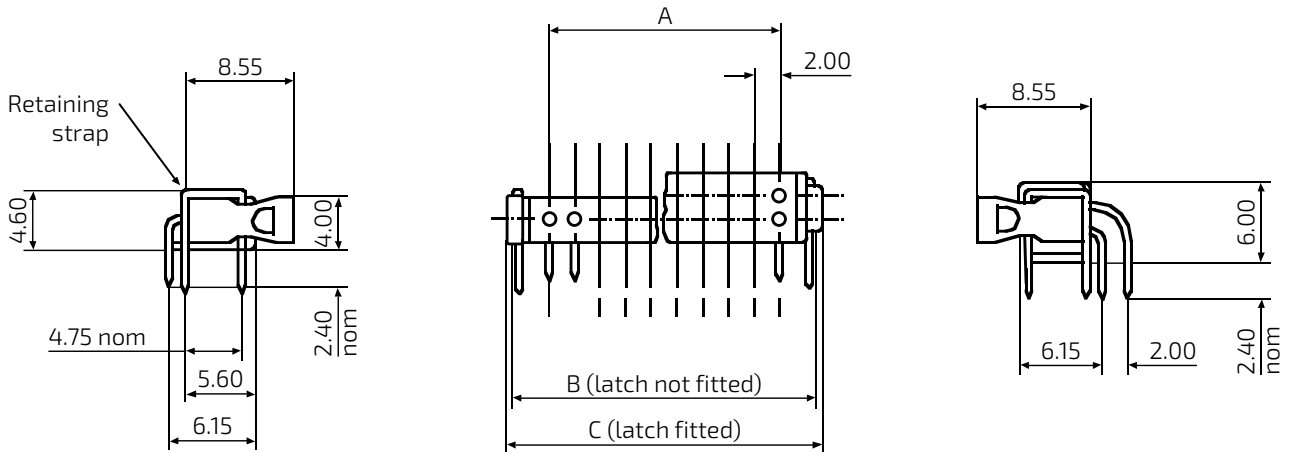

Female straight PC termination type T and N

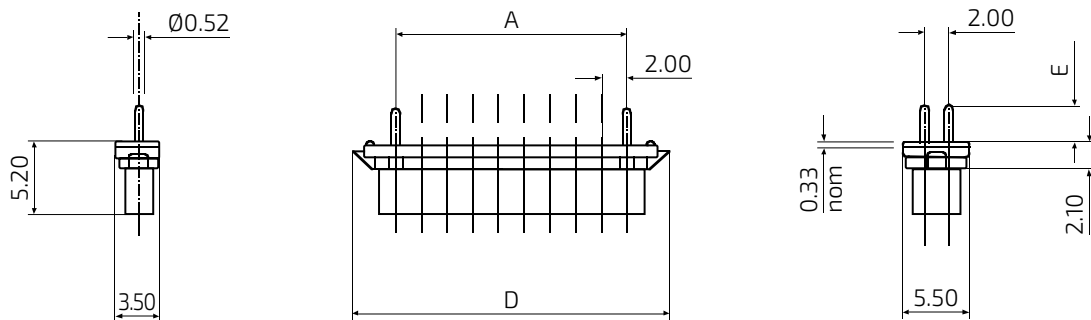

Note: All dimensions are in millimeters (mm).

Styles and Dimensions

Female crimp termination type C and D

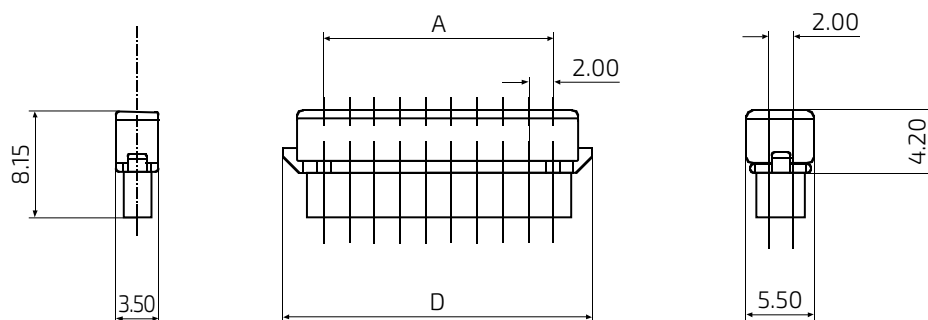

PCB layouts for male connectors type L

For male and female types T, X, Y and N omit 1.10/1.00 mm holes.

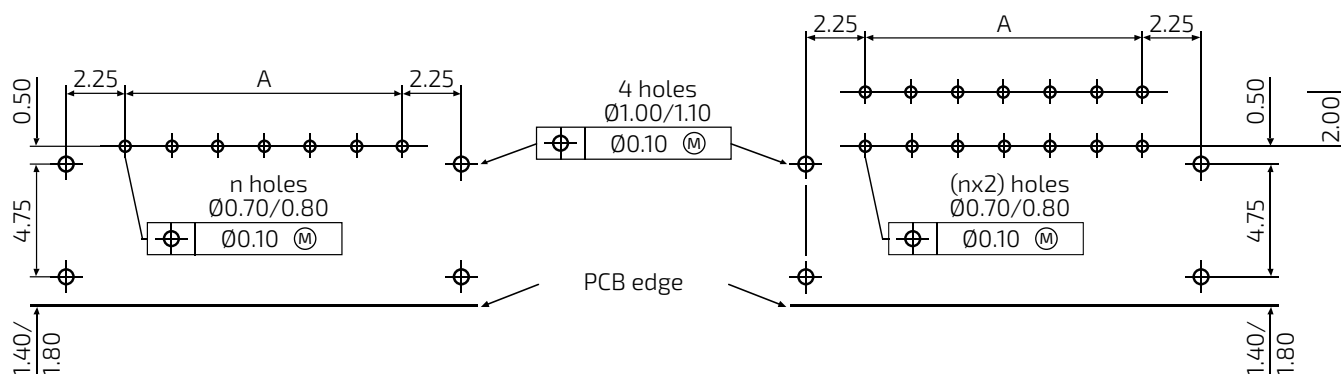

Plug viewed from above, socket viewed from below.

Contact Arrangement Single Row	Contact Arrangement Two Row	A	B	C	D
2	4	2.00	7.60	8.10	7.30
3	6	4.00	9.60	10.10	9.30
4	8	6.00	11.60	12.10	11.30
5	10	8.00	13.60	14.10	13.30
6	12	10.00	15.60	16.10	15.30
7	14	12.00	17.60	18.10	17.30
	16	14.00	19.60	20.10	19.30
	18	16.00	21.60	22.10	21.30
	20	18.00	23.60	24.10	23.30
	26	24.00	29.60	30.10	29.30
17	34	32.00	37.60	38.10	37.30

Termination Type	T	Y	X	N
E nom	2.90	5.35	9.35	1.10

Note: All dimensions are in millimeters (mm).

Minimum Spacing

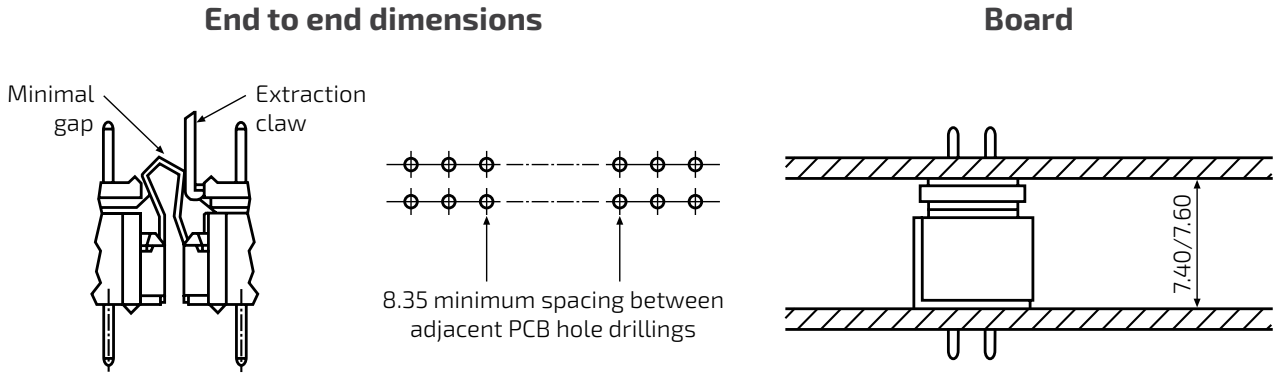

Crimp Details

Preferred wire type BS G 210 (Type A)



Termination Type	Crimp barrel accomodation	Wire size/crimp tool setting			
		22 A.W.G.	24 A.W.G.	26 A.W.G.	28 A.W.G.
C*	24-28 A.W.G.	-	7	6	6
D	22 A.W.G.	6	-	-	-

Whilst the crimp contact withdrawal tool is available as an optional accessory, it is only suitable for removing ALL contacts. The moulding MUST be replaced prior to reinsertion of the contacts.

Contact Arrangement

Viewed from mating face of male connector (17 and 34 way versions shown).

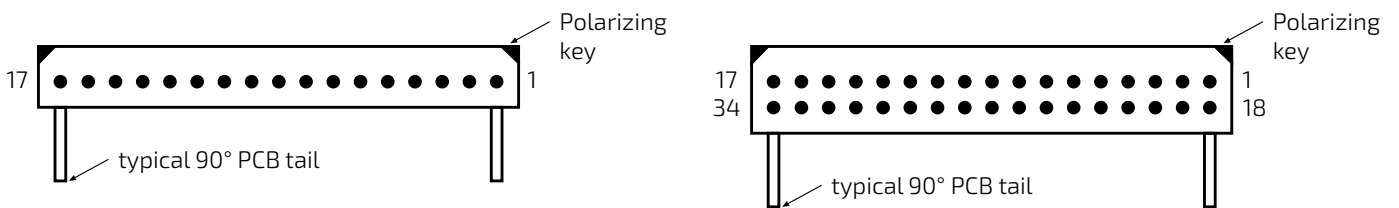

Note: All dimensions are in millimeters (mm).

* - Also suitable for use with 24 A.W.G. DEF-STAN 61-12 (Part 6 Type 1) PVC.

Connector Ordering Information

Weald part no example

LM201 M 17 T 01 L

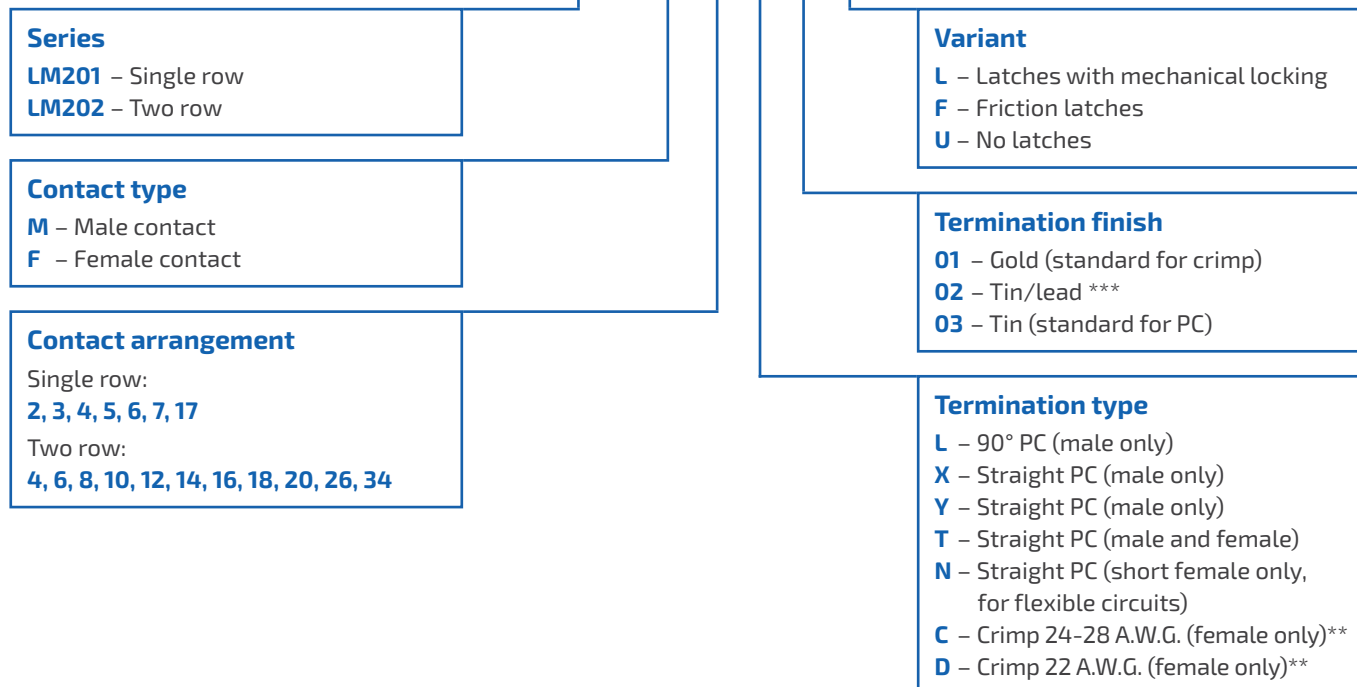

Tool Ordering Information

Tool name	Order code
Hand crimp tool	M22520/2-01
Crimp tool positioner	MP6818
Retaining strap	MP6759
Contact insertion and withdrawal tool kit	LMT/2/81092
Connector separating tool	T5746

** - To help minimise packaging, crimp connector mouldings and crimp contacts will be supplied in multiples of 10 per bag as standard. Please consult our sales office if alternative packaging is required.

*** - Please consult factory.

Product Safety Information

These notes are intended to be used in conjunction with the Product Catalogue and Product Specification. Products may be safely used in the applications for which they have been designed and within the specified rating and environments. If products are exposed to conditions outside the performance ratings or specified environments they may constitute a hazard. In particular it should be noted that:

1. Material Content

Circular Connectors generally use metalwork parts made of brass, aluminium, phosphor-bronze or steel, which, dependant on the particular application, may be passivated and protected with cadmium or zinc plate – in conjunction with chromated or anodised surface finishes. The insulating materials can either be natural or synthetic rubber, together with plastic or glass-filled plastic moulded parts. Contact materials vary but are usually made of brass, phosphor-bronze, alumel or chromel.

2. Electric Shock, Burns and Fire

Hazard can occur if the product is used outside the specified parameters or if the product is damaged, wrongly wired, poorly assembled, poorly integrated into larger equipments, or contaminated with conductive fluids. Live circuit terminations must be protected and live circuits never broken by disconnecting products.

Hot spots may be created when resistance is increased due to damage or incorrect integration particularly soldering, or loose terminations. Overheating can cause breakdown of insulation, electric shock, burns or, ultimately, fire. In the event of fire noxious and/or toxic fumes may be released and, in these circumstances, any fire involving the product should be dealt with by personnel properly equipped. Connectors with exposed terminations or contacts should not be used on the current supply side of a circuit with exposed contacts on an unmated product. Before making a circuit live, the product and wiring should be checked to ensure there is no electrically conducting debris present. Circuit resistance checks should also be conducted before making the circuit live. Always ensure that connectors are assembled and wired by properly trained personnel.

3. Use, Transport and Storage of Products

Care must be exercised to avoid damage to any part of the products during transporting, storage or use. Abnormal transit or storage conditions and abuse during installation can give rise to damage. Products should not be used in a damaged condition.

Improper storage (particularly of damaged products) can give rise to additional hazards particularly corrosion. Attention is specifically drawn to the need for proper storage of products containing cadmium and you are advised to see the Guidance Note from the Health and safety Executive on Cadmium – Health and Safety Precautions.

4. Disposal of Products

Product should not be burnt.

Safety Rules

- Follow the guidelines given
- Always protect live circuits and never disconnect a live connector
- Never use a damaged connector
- Never burn discarded connectors

Lodge Group

FC Lane Electronics Ltd

Franchised connector distributor

+44 (0) 1403 790 661
fclane.com



Weald Electronics Ltd

Manufacturers of high quality connectors and accessories

+44 (0) 1403 790 715
wealdelectronics.com



Lane Motorsport

Division of FC Lane dedicated to motorsport industry

+44 (0) 1403 790 661
lanemotorsport.com

