

## LMG HEAVY DUTY CONNECTORS

Ruggedised LMG range extension for use in extreme industrial applications.

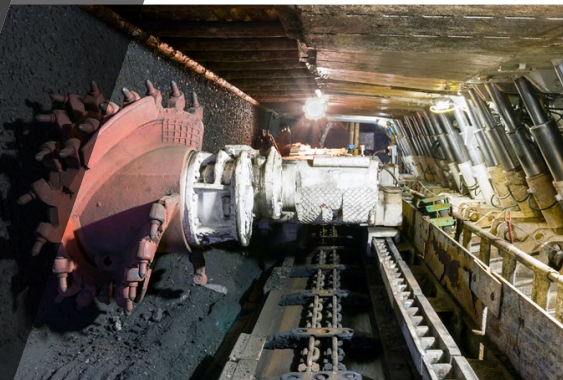



## Contents

Introduction	3
General information	4
Characteristics	5
Shell styles	6
Mating combinations	7
Contact arrangement and part numbers	8
Dimensions of type 1 connectors (Staple Coupling)	9-10
Dimensions of type 2 connectors (Threaded Coupling)	11
Accessories for type 1 connectors	12-13
Wiring instructions	14-16
Product safety information	18

## Lodge Group

Established in 1976, Weald Electronics is part of the Lodge Group which includes the connector distributor FC Lane Electronics and its Autosport Division, Lane Motorsport.



Lodge Group Headquarters

**Weald Electronics** is predominantly known for its comprehensive selection of circular bayonet and screw coupling connectors, and two-part PCB sub-miniature plastic-bodied circular connectors. Weald also specialises in short run, application specific, special and obsolete connector and cable developments.

To complete your interconnection solution, Weald manufactures protective caps and backshells for MIL-DTL-38999 and 26482 applications as well as protective caps, nut plates and gaskets for use right across motorsport.

With design, manufacturing and test facilities at its Slinfold Lodge HQ, Weald Electronics is able to tailor a connector solution to exactly meet a customer's specific requirement on surprisingly short lead times. Standard products are normally available next day.

Products from Weald Electronics Ltd are available from FC Lane Electronics Ltd.

t: +44 (0) 1403 790 661

e: [sales@fclane.com](mailto:sales@fclane.com)

w: [fclane.com](http://fclane.com)

## LMG Heavy Duty Range General Information

The high quality, extremely rugged LMG Heavy Duty connectors are ideal for use in a wide range of geophysical, mining, marine and petrochemical applications, where extreme strength and high reliability is essential. These include gas and oil exploration, heavy plant, tunnelling machines, concreting, steel industry, shipbuilding, power units, petrochemical, conveyors, marine and other heavy industrial applications.

### Features and Benefits

- High shock and vibration capabilities
- Environmentally sealed from IP67 to IP69
- 2 connector types: staple coupling and threaded coupling
- 2 to 19 gold plated contacts (5 to 19 amps rating)
- Shell material: Brass or Stainless Steel

### Ordering Information

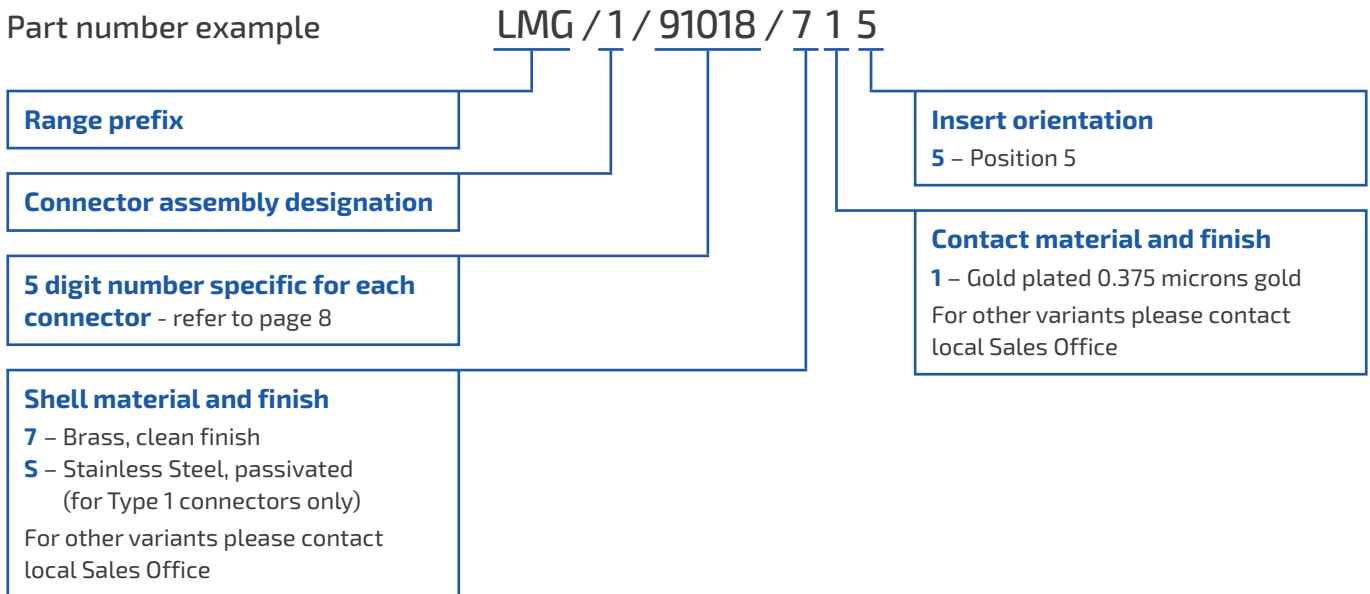

## Characteristics of Type 1 (Staple Coupling)

Temperature range	-55° to +100°C		
Maximum altitude	8474 metres		
Number of contacts	4, 12, 19		
Maximum current rating per individual contact at 70°C	5-19 amps dependent on contact size		
Contact finish	Gold plated (standard)		
Contact solder bucket	Rating	5 amps	19 amps
	Inside dia.	1.50 mm	2.75 mm
Working voltage DC or AC peak	500 or 700 volts at sea level (dependent on contact size)		
Polarization	None (fixed insert, one position only)		
Dielectric material	Polychloroprene		
Dielectric construction	Monobloc		
Sealing	Environmentally resistant with barrier or barrier and panel sealed (IP67)		
Housing material	Brass (clean finish) or Stainless Steel (passivated)		

## Characteristics of Type 2 (Threaded Coupling)

Temperature range	-55° to +100°C		
Maximum altitude	8474 metres		
Number of contacts	2, 3, 4		
Maximum current rating per individual contact at 70°C	7.5 amps		
Contact finish	Gold plated (standard)		
Contact solder bucket inside diameter	1.40 mm		
Working voltage DC or AC peak	700 volts at sea level		
Polarization	None (fixed insert, one position only)		
Dielectric material	Polychloroprene		
Dielectric construction	Monobloc		
Sealing	Environmentally resistant with barrier or barrier and panel sealed (equivalent to IP69K)		
Housing material	Brass (clean finish)		

## Shell Styles

Type 1 - staple coupling	<p><b>Free unit</b> Plug or socket</p> <p>See page 9</p>			<p><b>Mates with</b></p> <p>Fixed unit</p>
	<p><b>Fixed unit (square flange)</b> Plug or socket</p> <p>See page 9</p>			<p><b>Mates with</b></p> <p>Free unit</p>
	<p><b>Fixed unit (single hole front mounting)</b> Plug or socket</p> <p>See page 10</p>			<p><b>Mates with</b></p> <p>Free unit</p>
	<p><b>Fixed unit (single hole rear mounting)</b> Plug or socket</p> <p>See page 10</p>			<p><b>Mates with</b></p> <p>Free unit</p>
Type 2 - threaded coupling	<p><b>Free unit</b> Plug or socket connector for overmoulding</p> <p>See page 11</p>			<p><b>Mates with</b></p> <p>Fixed unit</p>
	<p><b>Fixed unit (M12 threaded hole front mounting)</b> Plug or socket</p> <p>See page 11</p>			<p><b>Mates with</b></p> <p>Free unit</p>

## Mating Combinations

### Type 1 - Staple Coupling

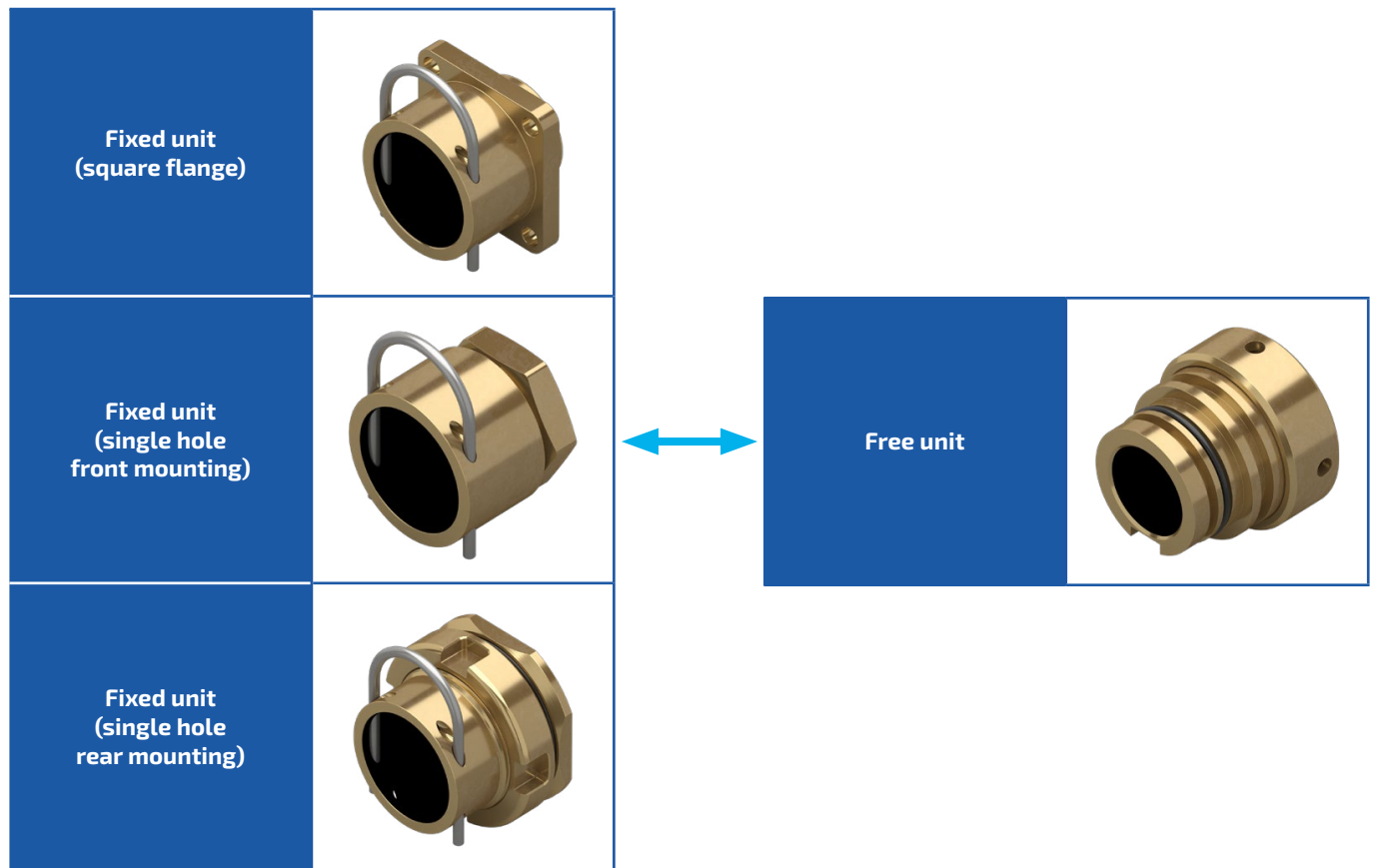

### Type 2 - Threaded Coupling

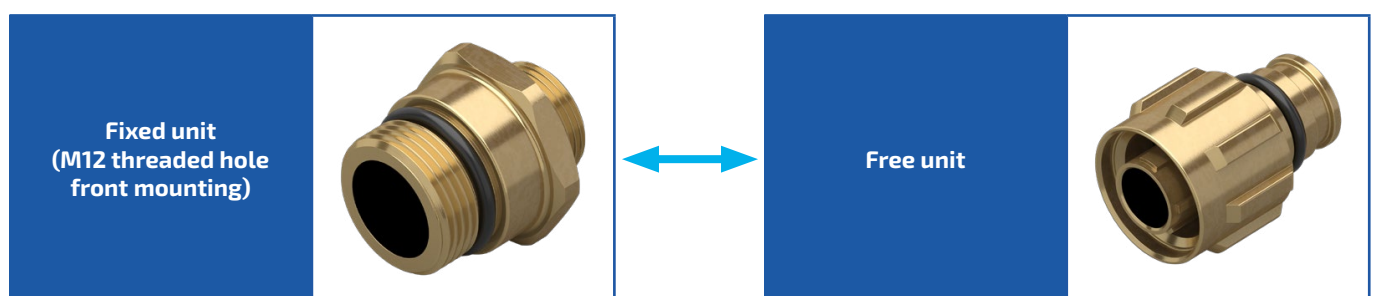

 All LMG Heavy Duty connectors can be supplied with male and female contacts/mouldings and can be mated in combinations as shown above.

### Contact Arrangement and Part Numbers

#### Type 1 - Staple Coupling

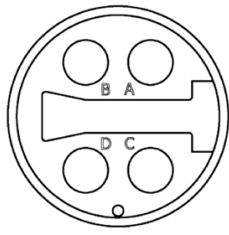
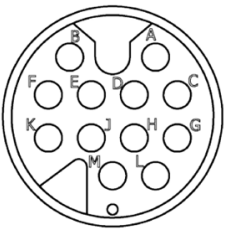
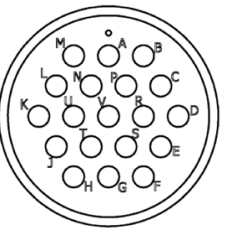
Contact arrangement		
		
4 way 19 amps, 500 volts	12 way 5 amps, 500 volts	19 way 5 amps, 700 volts

Connector style	Part number		
Free plug	LMG/1/91018/715	LMG/1/91036/715	LMG/1/91022/715
Free socket	LMG/1/91019/715	LMG/1/91021/715	LMG/1/91023/715
Fixed plug (square flange)	LMG/1/91000/715	LMG/1/91002/715	LMG/1/91004/715
Fixed socket (square flange)	LMG/1/91001/715	LMG/1/91003/715	LMG/1/91005/715
Fixed plug (single hole front mounting)	LMG/1/91006/715	LMG/1/91008/715	LMG/1/91010/715
Fixed socket (single hole front mounting)	LMG/1/91007/715	LMG/1/91009/715	LMG/1/91011/715
Fixed plug (single hole rear mounting)	LMG/1/91012/715	LMG/1/91014/715	LMG/1/91016/715
Fixed socket (single hole rear mounting)	LMG/1/91013/715	LMG/1/91015/715	LMG/1/91017/715

#### Type 2 - Threaded Coupling

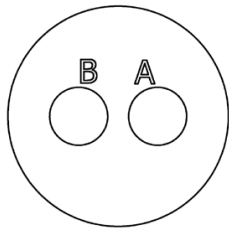
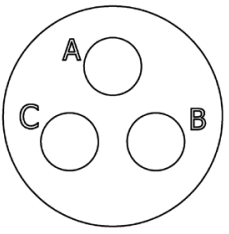
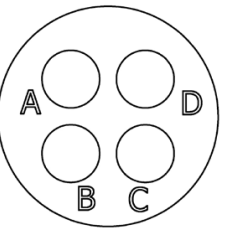
Contact arrangement		
		
2 way 7.5 amps, 700 volts	3 Way 7.5 amps, 700 volts	4 Way 7.5 amps, 700 volts

Connector style	Part number		
Free plug	LMG/1/91024/715	LMG/1/91026/715	LMG/1/91028/715
Free socket	LMG/1/91025/715	LMG/1/91027/715	LMG/1/91029/715
Fixed plug	LMG/1/91030/715	LMG/1/91032/715	LMG/1/91034/715
Fixed socket	LMG/1/91031/715	LMG/1/91033/715	LMG/1/91035/715

 The part numbers above are for the most common variants (Brass, clean finish). For other variants see Ordering Information on page 4. For mating combinations refer to page 7.

Note: Drawings not to scale.

## Dimensions of Type 1 (Staple Coupling)

Free plugs and sockets

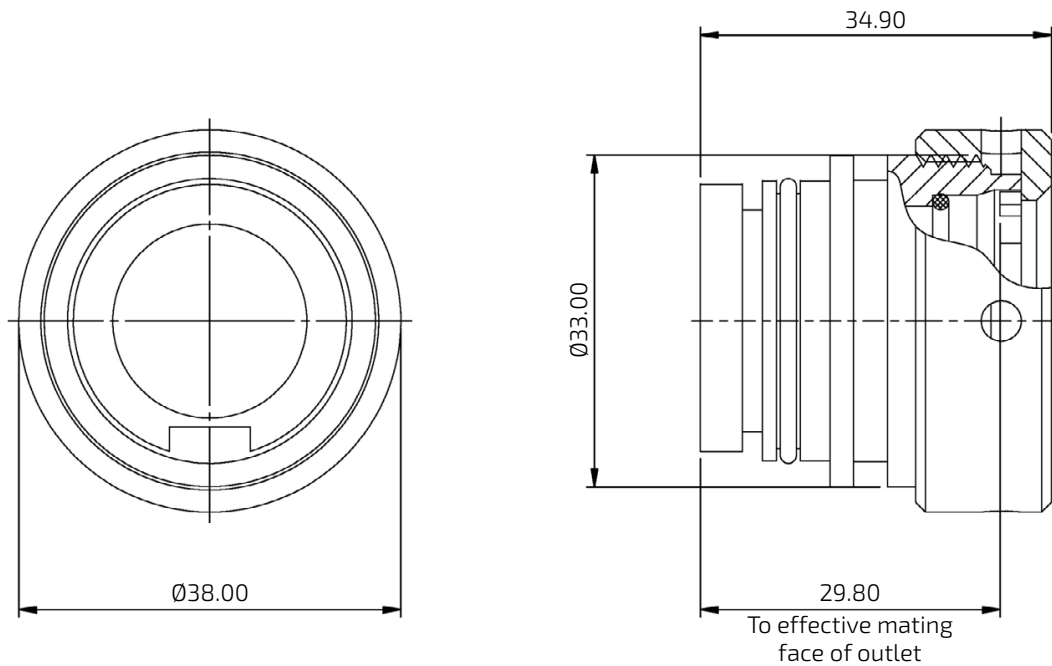

For backend accessories see page 12.

Fixed square flange plugs and sockets

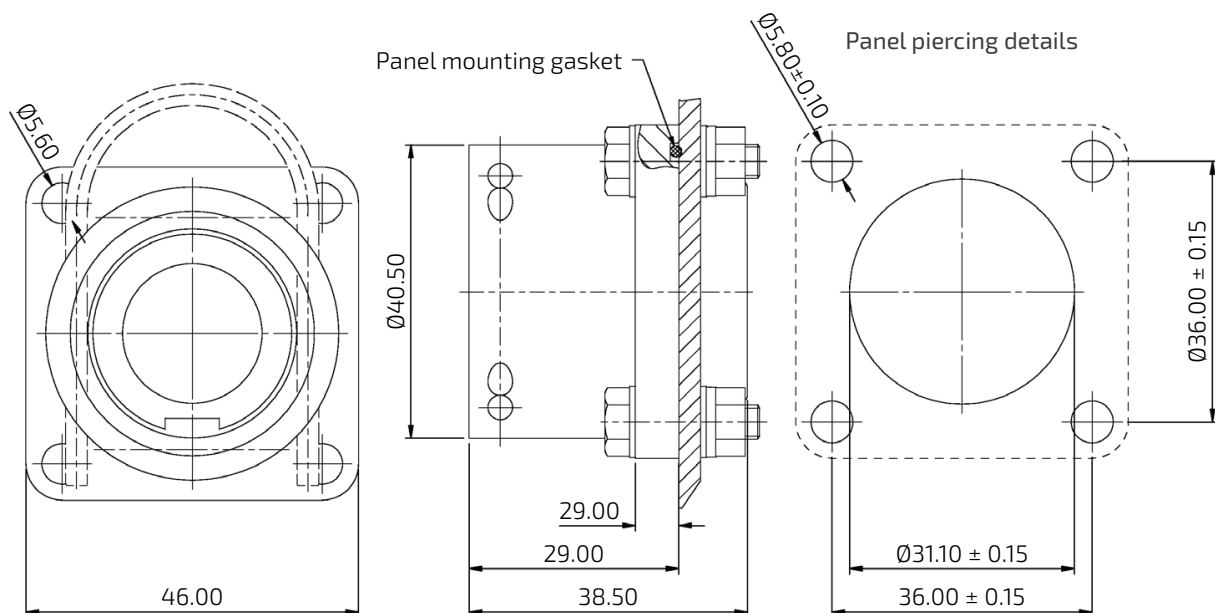

Continued on next page

Note: All dimensions are in millimeters (mm).

### Dimensions of Type 1 (Staple Coupling)

Single hole front mounting plugs and sockets

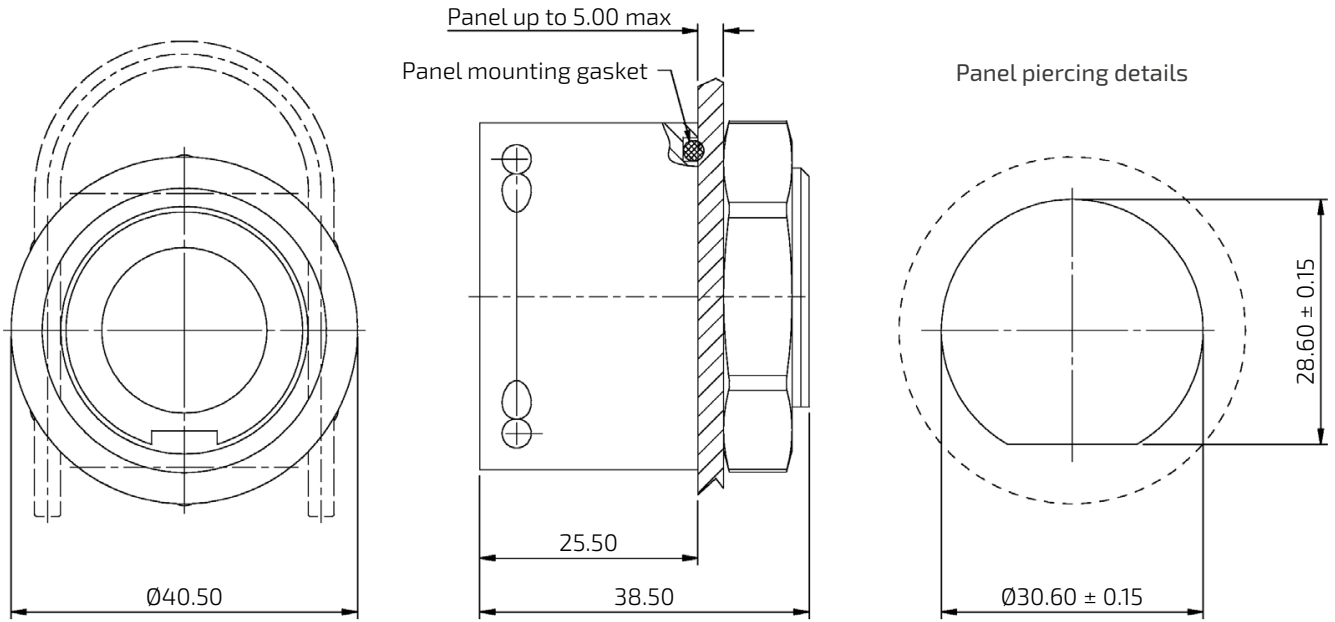

Single hole rear mounting plugs and sockets

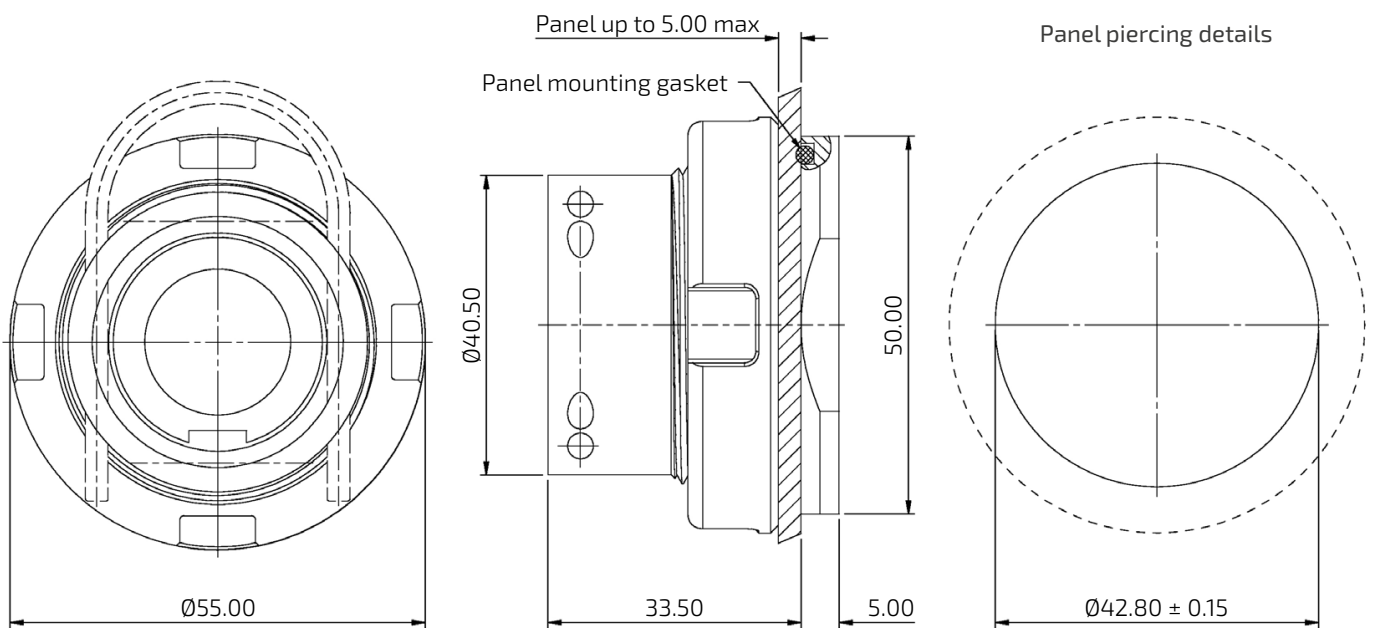

Note: All dimensions are in millimeters (mm).

## Dimensions of Type 2 (Threaded Coupling)

Free plugs and sockets for overmoulding

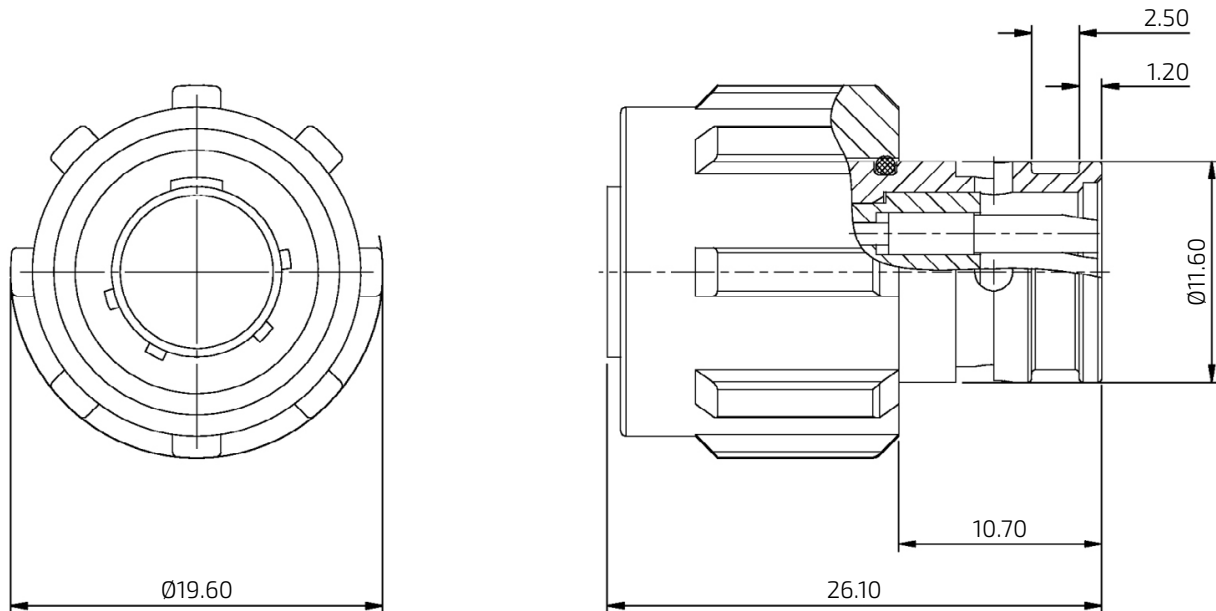

Single hole front mounting plugs and sockets

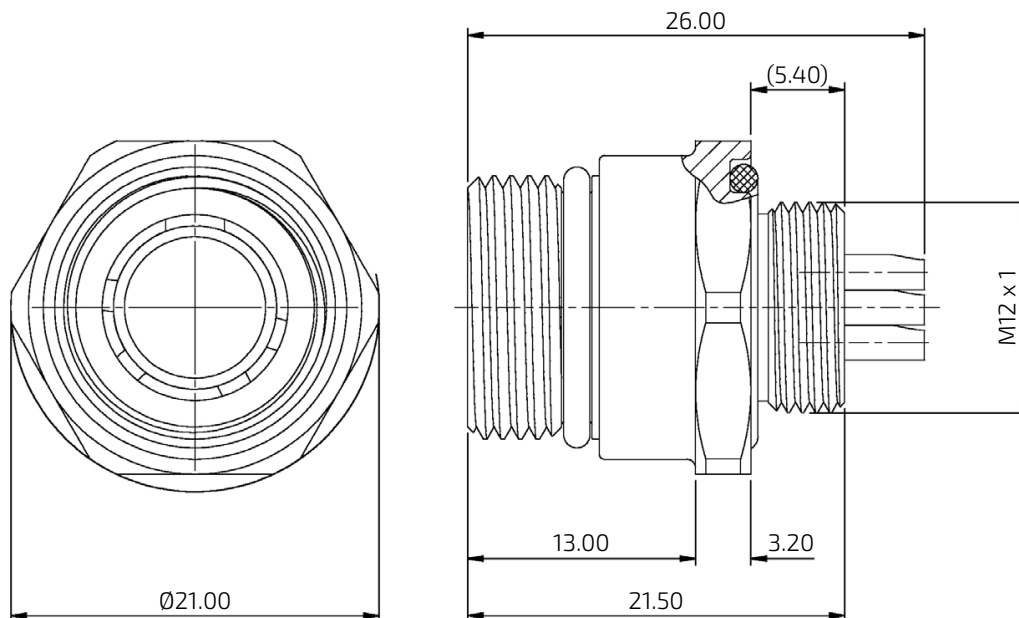

Mounting hole must have M12 x 1 thread.

Note: All dimensions are in millimeters (mm).

## Accessories for Connectors Type 1 - Ordering Information

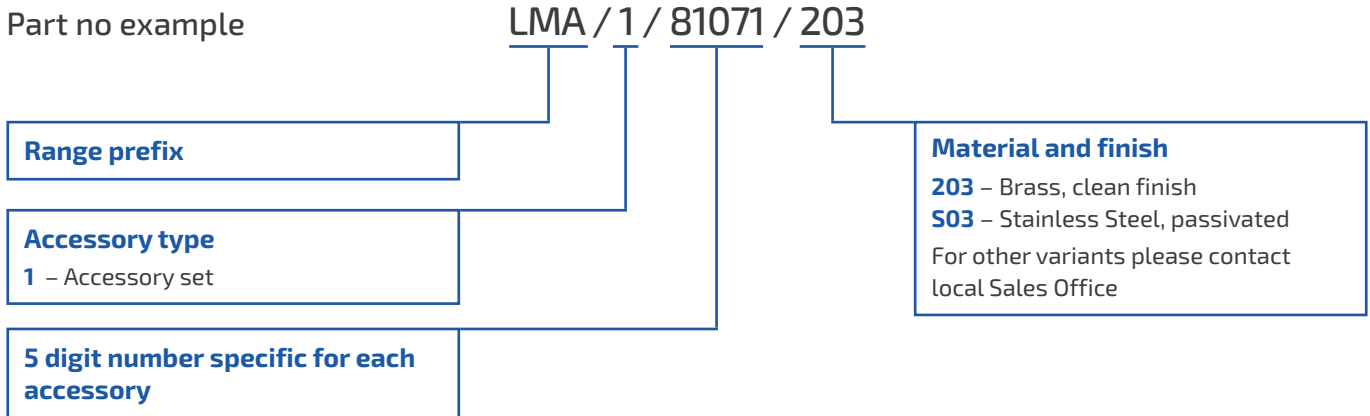

## Outlet Accessory Set for Screened and Unscreened Multicore Cable

For use with multicore unscreened cables or cables with an inner collective screen. Designated for Type 1 free connectors only.

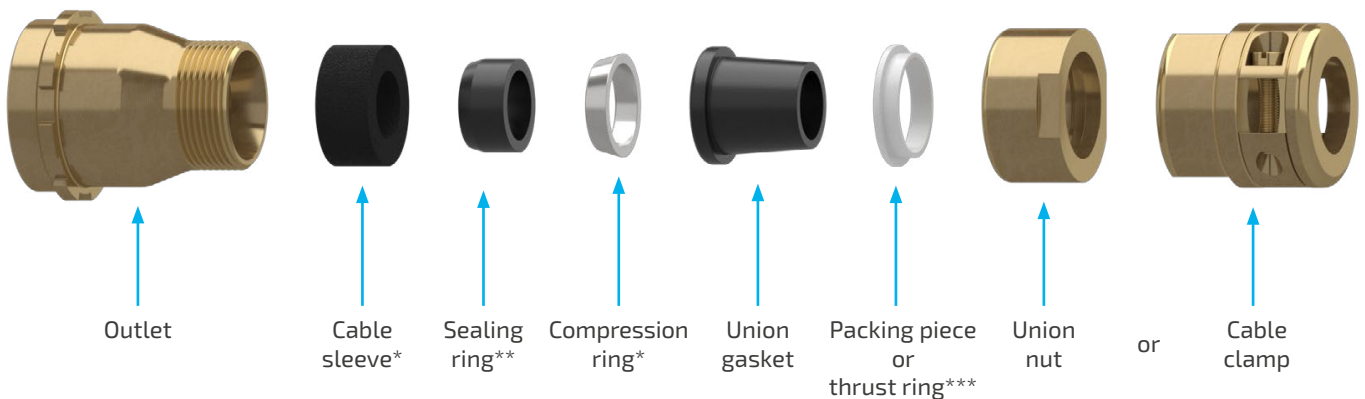

Cable O/D		Approximate length excluding Union Gasket (with Union Nut / Cable Clamp)	Outlet Accessory Set with Union Nut	Outlet Accessory Set with Cable Clamp
Min	Max			
8.80	11.20	46 / 60	LMA/1/81069/203	LMA/1/81070/203
11.20	13.10	46 / 60	LMA/1/81071/203	LMA/1/81072/203
18.00	18.60	52 / 66	LMA/1/81089/203	LMA/1/81087/203
18.00	18.60	72 / 86	LMA/1/81100/203	LMA/1/81099/203

- !** The part numbers above are for the most common variants (Brass, clean finish). For other variants see Ordering Information.
- \* - Parts to be used for screened cable only. For assembly instruction see pages 14 - 15.
  - \*\* - Part to be used for unscreened cable only. For assembly instruction see page 16.
  - \*\*\* - Metal thrust ring is supplied with LMA/1/81087/203 and LMA/1/81089/203 accessory sets.

Note: All dimensions are in millimeters (mm).

## Other Accessories

	Accessory	Part number
	Protective cap for type 1 free connectors	LMA/2/81095
	Protective cap for type 1 fixed connectors	LMA/2/81096

	Accessory	Part number
	Staple for type 1 fixed connectors	LMA/2/81075

	Accessory	Part number
	Spanner for type 1 single hole front mounting connector (locking nut)	LMT/2/81076

	Accessory	Part number
	Spanner for type 1 free connector (outlet nut)	LMT/2/81077



## Connector Wiring Instructions

Multicore cable with inner collective screen

### 1. Strip outer sheath and braid.

Thread on union nut / cable clamp, packing piece or thrust ring\*, union gasket (see note), compression ring and cable sleeve.

Comb out metal braid, fold back over sheath and tape down.

Strip insulation from conductors and tin dip.

Thread on outlet nut and outlet. Fit insulating sleeves to each conductor.

Union gasket requires to be a close fit to cable sheath. Synthetic rubber sleeve/s to be fitted to achieve a satisfactory fit.

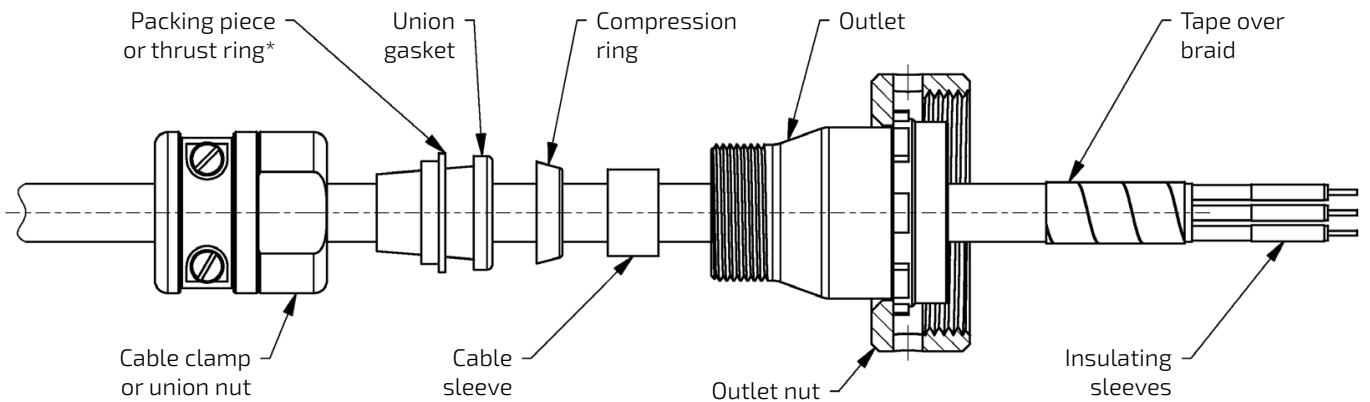

### 2. Solder conductors to connector contacts and slide insulating sleeves over soldered joints.

Position outlet at rear of connector and secure with outlet nut.

Slide cable sleeve into neck of outlet.

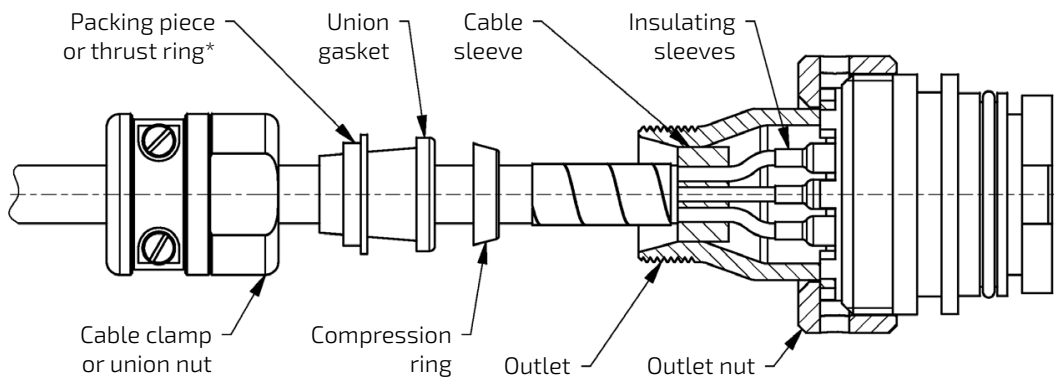

\* - Metal thrust ring is supplied with LMA/1/81087/203 and LMA/1/81089/203 accessory sets.

## Connector Wiring Instructions

Multicore cable with inner collective screen

**3.** Remove tape from metal braid and fan out 90° to cable.

Position compression ring on end of outer sheath trapping braid between outlet and compressions ring.

Slide forward union gasket and thrust ring to rear of compression ring.

Trim off braid, to rear face of compression ring and screw union nut / cable clamp onto outlet.

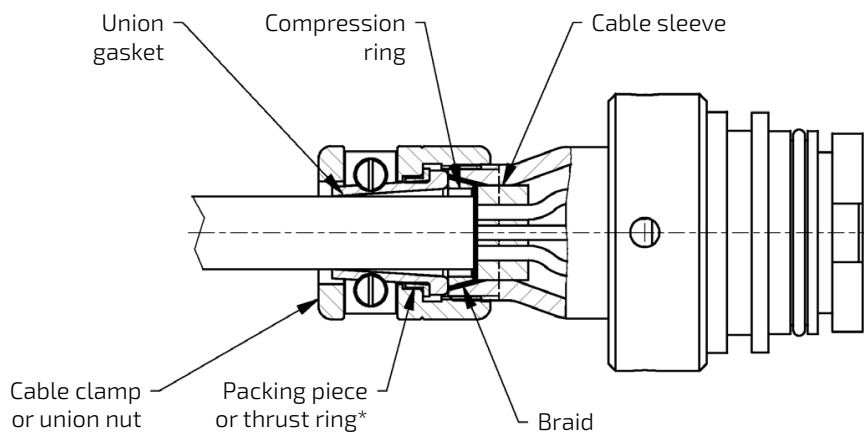

\* - Metal thrust ring is supplied with LMA/1/81087/203 and LMA/1/81089/203 accessory sets.

## Wiring Instructions

Multicore cable unscreened

### 1. Strip back outer sheath.

Strip insulation from each conductor and tin dip.

Thread on to cable:- union nut / cable clamp, packing piece, union gasket (see note), outlet and outlet nut.

Fit insulation sleeves to conductors.

Union gasket requires to be a close fit to cable sheath. Synthetic rubber sleeve/s to be fitted to achieve a satisfactory fit.

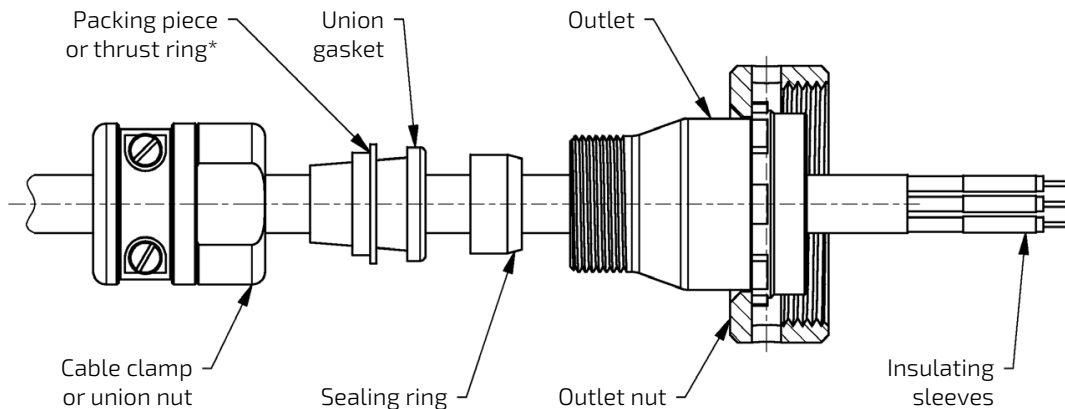

### 2. Solder conductors to connector contacts.

Slide insulation sleeves over solder joints.

Position outlet at rear of connector and secure with outlet nut.

Slide union gasket into neck of outlet. Screw clamp on to outlet.

Secure union nut / cable clamp to cable by screwing down clamp jaw.

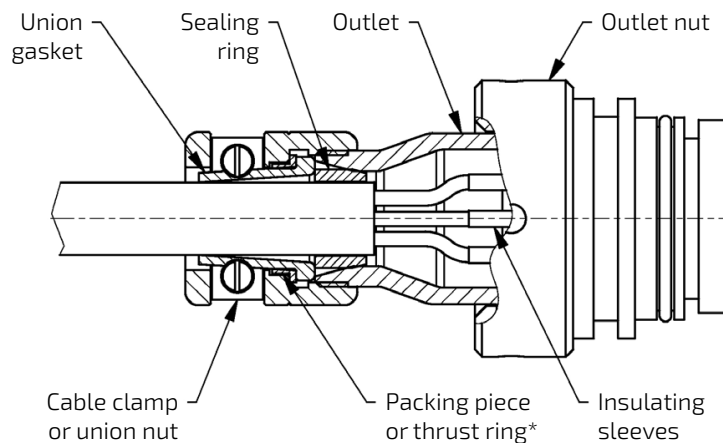

\* - Metal thrust ring is supplied with LMA/1/81087/203 and LMA/1/81089/203 accessory sets.



## Product Safety Information

**These notes are intended to be used in conjunction with the Product Catalogue and Product Specification. Products may be safely used in the applications for which they have been designed and within the specified rating and environments. If products are exposed to conditions outside the performance ratings or specified environments they may constitute a hazard. In particular it should be noted that:**

### 1. Material Content

Circular Connectors generally use metalwork parts made of brass, aluminium, phosphor-bronze or steel, which, dependant on the particular application, may be passivated and protected with cadmium or zinc plate – in conjunction with chromated or anodised surface finishes. The insulating materials can either be natural or synthetic rubber, together with plastic or glass-filled plastic moulded parts. Contact materials vary but are usually made of brass, phosphor-bronze, alumel or chromel.

### 2. Electric Shock, Burns and Fire

Hazard can occur if the product is used outside the specified parameters or if the product is damaged, wrongly wired, poorly assembled, poorly integrated into larger equipments, or contaminated with conductive fluids. Live circuit terminations must be protected and live circuits never broken by disconnecting products.

Hot spots may be created when resistance is increased due to damage or incorrect integration particularly soldering, or loose terminations. Overheating can cause breakdown of insulation, electric shock, burns or, ultimately, fire. In the event of fire noxious and/or toxic fumes may be released and, in these circumstances, any fire involving the product should be dealt with by personnel properly equipped. Connectors with exposed terminations or contacts should not be used on the current supply side of a circuit with exposed contacts on an unmated product. Before making a circuit live, the product and wiring should be checked to ensure there is no electrically conducting debris present. Circuit resistance checks should also be conducted before making the circuit live. Always ensure that connectors are assembled and wired by properly trained personnel.

### 3. Use, Transport and Storage of Products

Care must be exercised to avoid damage to any part of the products during transporting, storage or use. Abnormal transit or storage conditions and abuse during installation can give rise to damage. Products should not be used in a damaged condition.

Improper storage (particularly of damaged products) can give rise to additional hazards particularly corrosion. Attention is specifically drawn to the need for proper storage of products containing cadmium and you are advised to see the Guidance Note from the Health and safety Executive on Cadmium – Health and Safety Precautions.

### 4. Disposal of Products

Product should not be burnt.

## Safety Rules

- Follow the guidelines given
- Always protect live circuits and never disconnect a live connector
- Never use a damaged connector
- Never burn discarded connectors

## Lodge Group

---

### FC Lane Electronics Ltd

Franchised connector distributor

+44 (0) 1403 790 661  
fclane.com



### Weald Electronics Ltd

Manufacturers of high quality connectors and accessories

+44 (0) 1403 790 715  
wealdelectronics.com



### Lane Motorsport

Division of FC Lane dedicated to motorsport industry

+44 (0) 1403 790 661  
lanemotorsport.com

